

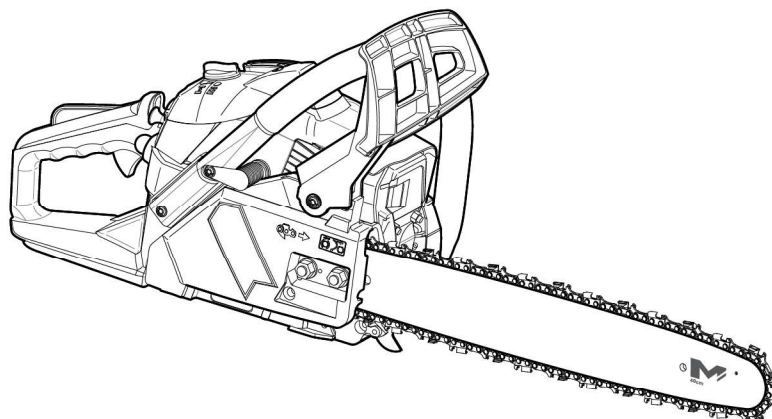

EN	40cc Petrol Chain Saw - OPERATOR'S MANUAL WARNING: read thoroughly the instruction booklet before using the machine.	2
FR	Scie à chaîne à essence 40 cc - MANUEL D'UTILISATION ATTENTION: lire attentivement le manuel avant d'utiliser cette machine.	60
PL	Benzynowa pilarka łańcuchowa 40 cm³ - INSTRUKCJA OBSŁUGI OSTRZEŻENIE: przed użyciem maszyny dokładnie przeczytać instrukcję.	118
RU	40cc Бензопила - РУКОВОДСТВО ПО ЭКСПЛУАТАЦИИ ОСТОРОЖНО: прежде чем использовать машину, внимательно прочтите данное руководство.	176
ES	Motosierra con motor de combustión de 40cc MANUAL DE INSTRUCCIÓN ADVERTENCIA: Lea atentamente todo el manual antes de utilizar el producto y guárdelo para futura referencia.	234
PT	Motosserra a Gasolina de 40 cc - MANUAL DE INSTRUÇÕES AVISO: leia atentamente o folheto de instruções antes de utilizar a máquina.	292
RO	Ferăstrău cu lanț pe benzină, 40 cm³ - MANUAL DE UTILIZARE AVERTISMENT: citiți în întregime broșura cu instrucțiuni înainte de a utiliza mașina.	350



MCSWP40

EAN: 3663602627548

Let's get started...

These instructions are for your safety. Please read through them thoroughly before use and retain them for future reference.



Getting **started**... 02

Technical and legal information 03

Your product 13

Before you start 17

Quick Start 26



In more detail... 29

Product functions 30

Operation 35

Care and maintenance 43

Trouble shooting 54

Recycling and disposal 55

Guarantee 56

EC declaration of conformity 57

Safety warnings

- > This product is not intended for use by persons (including children) with reduced physical, sensory or mental capabilities, or lack of experience and knowledge, unless they have been given supervision or instruction concerning use of the product by a person responsible for their safety;
- > Children should be supervised to ensure that they do not play with the product.

General

- > This product is dangerous if used carelessly or incorrectly and can cause serious or even fatal injuries.
- > Read all instructions carefully. When using petrol powered products, always follow stated safety precautions to reduce the risk of serious personal injury and/or damage to the product.
- > The product should only be operated by those who have read and understood all safety and operating instructions in this manual.
- > Keep your work area free from pets, animals, children and bystanders.
- > Follow instructions for lubricating, chain tensioning and changing accessories. Improperly tensioned or lubricated chain may either break or increase the chance for kickback. It may cause the chain to snap, which could lead to serious or even fatal injuries.
- > Running this product in a confined or badly ventilated area can result in death due to asphyxiation or carbon monoxide poisoning. The product is for outdoor use only.
- > Take extreme care in wet and freezing weather conditions. Do not work in rain, windy or stormy weather.
- > Do wear a face and breathing mask. The use of this product can generate dust, mists and fumes containing chemicals known to cause respiratory damage.
- > Do use safety steel toe capped footwear, sturdy cut retardant snug-fitting protective clothing, protective gloves, eye, hearing and head protection devices.
- > Do always visually check the product before use.
- > Do not attempt to tackle any job that you are not adequately trained for.
- > Do not allow other persons to be near when starting or cutting with the product.
- > Keep bystanders and animals at least 15 metres (50') out of the work area.
- > Do not operate the product if it has faulty safety equipment or

damaged parts!

- > Do not under any circumstances modify the product. Modifications can result in serious personal injury or death.
- > Do not start cutting until you have a clear work area, secure footing, and a planned retreat path from the falling tree.
- > All product servicing & maintenance, other than the items listed in the user manual, safety and maintenance instructions, should be performed by an authorised service centre.
- > A first time user should have practical instruction in the use of the product and protective equipment from an experienced operator.
- > National regulation can restrict the use of the product.

Clothing and protective equipment

- > Do secure long hair so that it is above shoulder level.
- > Do not wear loose fitting clothing or jewellery as this could be drawn into the engine, catch the chain or undergrowth.
- > Use the following safety clothing and protective equipment when operating the product:
 - > Helmet with visor and neck guard - (EN397 compliant),
 - > Hearing protectors,
 - > Breathing mask,
 - > Gloves with approved saw protection (compliant to EN 381-4, EN 381-7, EN420:1, EN 388 Class 0),
 - > Protective leggings with approved saw protection (compliant to EN 381-5, EN 340 Class 1),
 - > Steel toe cap boots with approved saw protection (compliant to EN 345-2 Class 2),
 - > First Aid kit in case of injury.

Fuel handling

- > Fuel vapour pressure may build up inside the fuel tank depending on the fuel used, weather conditions and the tank venting system. To reduce the risk of burns and other personal injuries, remove the filler cap carefully to allow any pressure build up to release slowly.
- > Fuel and fuel vapour are highly flammable. Take care when handling fuel and chain oil.
- > Be aware of fire risks, explosion and inhalation risk.
- > Do not smoke while operating the product, handling fuel or near fuel.
- > Ensure the spark plug lead is secure, a loose lead may cause electrical arcing that could ignite combustible fumes and cause a fire or explosion.
- > Do always switch off the engine first before refilling the fuel or oil tanks.

- > Do keep chain oil levels topped up, failure to maintain oil levels will damage your product and shorten the chain life.
- > Do check regularly for leaks from the fuel cap and fuel lines.
- > Do use caution when handling fuel. To avoid any accidental fires, move the product at least 3 metres (10') from the fuelling point before starting the engine.
- > Do tighten the fuel cap thoroughly after refilling the fuel tank.
- > Do not operate the product if it is leaking fuel or chain oil.
- > Do not remove the fuel tank cap while the engine is running.
- > Do not store cans of fuel or refill the fuel tank in any place where there is a boiler, stove, wood fire, electrical sparks, welding sparks, or other sources of heat or fire which might ignite the fuel.
- > If any fuel spillage occurs during refuelling, use a dry rag to wipe up spills and allow remaining fuel to evaporate before turning the engine on again.
- > If you have spilt fuel on yourself or on your clothes, change your clothes and wash any part of your body that has come in contact with fuel before turning the engine on again.
- > If fuel is ignited, put out the fire with a dry powder fire extinguisher.

Getting started

- > Do not operate the product indoors, it produces poisonous exhaust fumes whilst the engine is running and may be colourless and odourless.
- > Do not wrap the recoil starter rope around your hand whilst starting the product. This may result in injuries to your hand or fingers.
- > Do keep handles dry, clean, and free from oil and grease. Greasy, oily handles are slippery causing loss of control.
- > Do not operate the product with a slack chain. A slack chain may jump off the guide bar and cause serious or even fatal injury.
- > Do not operate the product with one hand! Serious injury to the operator or bystanders may result from one handed operation.
- > Keep all parts of the body away from the saw chain when the chain saw is operating. Before you start the chain saw, make sure the saw chain is not contacting anything and free from obstructions. A moment of inattention while operating chain saws may cause entanglement of your clothing or body with the saw chain.
- > Do shut off the engine before setting the product down.
- > Before using the product and after any impact or dropping, check for signs of wear or damage and repair as necessary.

Operation

- > When sawing ensure the product does not touch any foreign materials such as rocks, fences, nails etc. Such objects may be flung off and

could result in damage to the product or serious personal injury or even death.

- > Never operate the product on a ladder or other insecure support.
- > Stop the engine if the chain jams in the cut. Do not try to pull the product free. Use a lever to open the cut and free the chain. Failure to do so could result in serious injuries or death.
- > Do only cut with the engine at high speed in order to avoid blockage.
- > Do use extreme caution when cutting small size bushes and saplings. Slender material may catch the saw chain and whip toward you or put you off balance.
- > Do operate the product only in well ventilated areas.
- > Do not operate the product with one hand! This product is intended for two handed use only, with your right hand on the rear handle and your left hand on the front handle. You cannot control reactive forces and you may lose control of the saw, which can result in the skating or bouncing of the bar and chain along the limb or log.
- > Do not operate the product if you are tired or ill.
- > Do not operate the product if you have any medical conditions that might be aggravated by strenuous work. Check with your doctor before operating this product.
- > Do not operate the product under the influence of drugs, alcohol or medication.
- > Do not touch the exhaust during use – it gets very hot.
- > Do not operate a product that is damaged, improperly adjusted, or not completely and securely assembled. Be sure that the saw chain stops moving when the throttle trigger is released.
- > Do not operate this product in a tree. Operation of the product while up in a tree may result in personal injury.
- > Do not operate your product near or around flammable liquids or gases.
- > Do not smoke whilst operating the product.
- > Do not lock the product over fixed stands.
- > Do not operate the product indoors, it produces poisonous exhaust fumes whilst the engine is running and may be colourless and odourless.
- > Do not grip the handles with constant or excessive pressure; this will increase the feeling of vibration and the risk of 'whitefinger' disease.
- > Do not over reach when operating the product or cut above shoulder height.
- > Do not operate the product if it is leaking fuel or chain oil.
- > When cutting a limb (branch) that is under tension, be alert for spring back so that you will not be struck when the tension in the wood fibres

is released.

- > Always keep proper footing and operate the chain saw only when standing on fixed, secure and level surface. Slippery or unstable surfaces such as ladders may cause a loss of balance or control of the chain saw.
- > Cut wood only. Do not use the product for purposes not intended. For example: do not use chain saw for cutting plastic, masonry or non-wood building materials. Use of the chain saw for operations different than intended could result in a hazardous situation.

Transport and storage

- > Do ensure the engine is off and engage the chain brake before transporting the product.
- > Do carry the product with the engine stopped, the guide bar and saw chain to the rear, and the exhaust away from your body.
- > Do use the guide bar cover and ensure that is fitted to the product during transportation or storage.
- > Only carry the product in a horizontal position. Grip the front handle in a manner that the product is balanced horizontally.
- > Keep the hot exhaust away from your body and the saw chain behind you.
- > Correctly secure your product when transporting in a vehicle to prevent turnover, fuel spillage and damage to the product
- > Always store the product and fuel so that there is no risk of leakages or fumes coming into contact with sparks or naked flames from electrical equipment, electric motors, relays/switches, boilers etc.
- > For longer periods of storage or transportation the fuel and chain oil tanks must be emptied. Dispose of waste oil and fuel at a local authority centre or where facilities exist.
- > Do store fuel in an approved container designed for that purpose.
- > Do ensure that the product is cleaned and that a complete service is conducted before any long-term storage.

Additional safety warnings

- > **Keep all parts of the body away from the saw chain when the chain saw is operating. Before you start the chain saw, make sure the saw chain is not contacting anything.** A moment of inattention while operating chain saws may cause entanglement of your clothing or body with the saw chain.
- > **Always hold the chain saw with your right hand on the rear handle and your left hand on the front handle.** Holding the chain saw with a reversed hand configuration increases the risk of personal injury and should never be done.

- > **Wear safety glasses and hearing protection. Further protective equipment for head, hands, legs and feet is recommended.** Adequate protective clothing will reduce personal injury by flying debris or accidental contact with the saw chain.
- > **Do not operate a chain saw in a tree.** Operation of a chain saw while up in a tree may result in personal injury.
- > **Always keep proper footing and operate the chain saw only when standing on fixed, secure and level surface.** Slippery or unstable surfaces such as ladders may cause a loss of balance or control of the chain saw.
- > **When cutting a limb that is under tension be alert for spring back.** When the tension in the wood fibres is released the spring loaded limb may strike the operator and/or throw the chain saw out of control.
- > **Use extreme caution when cutting brush and saplings.** The slender material may catch the saw chain and be whipped toward you or pull you off balance.
- > **Carry the chain saw by the front handle with the chain saw switched off and away from your body. When transporting or storing the chain saw always fit the guide bar cover.** Proper handling of the chain saw will reduce the likelihood of accidental contact with the moving saw chain.
- > **Follow instructions for lubricating, chain tensioning and changing accessories.** Improperly tensioned or lubricated chain may either break or increase the chance for kickback.
- > **Keep handles dry, clean, and free from oil and grease.** Greasy, oily handles are slippery causing loss of control.
- > **Cut wood only. Do not use chain saw for purposes not intended. For example: do not use chain saw for cutting plastic, masonry or non-wood building materials.** Use of the chain saw for operations different than intended could result in a hazardous situation.

Causes and operator prevention of kickback

Kickback may occur when the nose or tip of the guide bar touches an object, or when the wood closes in and pinches the saw chain in the cut.

Tip contact in some cases may cause a sudden reverse reaction, kicking the guide bar up and back towards the operator.

Pinching the saw chain along the top of the guide bar may push the guide bar rapidly back towards the operator.

Either of these reactions may cause you to lose control of the saw

which could result in serious personal injury. Do not rely exclusively upon the safety devices built into your saw. As a chain saw user, you should take several steps to keep your cutting jobs free from accident or injury.

Kickback is the result of tool misuse and/or incorrect operating procedures or conditions and can be avoided by taking proper precautions as given below:

- > **Maintain a firm grip, with thumbs and fingers encircling the chain saw handles, with both hands on the saw and position your body and arm to allow you to resist kickback forces.** Kickback forces can be controlled by the operator, if proper precautions are taken. Do not let go of the chain saw.
- > **Do not overreach and do not cut above shoulder height.** This helps prevent unintended tip contact and enables better control of the chain saw in unexpected situations.
- > **Only use replacement bars and chains specified by the manufacturer.** Incorrect replacement bars and chains may cause chain breakage and/or kickback.
- > **Follow the manufacturer's sharpening and maintenance instructions for the saw chain.** Decreasing the depth gauge height can lead to increased kickback.

Vibration and noise reduction

To reduce the impact of noise and vibration emission, limit the time of operation, use low-vibration and low-noise operating modes as well as wear personal protective equipment.

Take the following points into account to minimize the vibration and noise exposure risks:

- > Only use the product as intended by its design and these instructions.
- > Ensure that the product is in good condition and well maintained.
- > Use correct application tools for the product and ensure they are in good condition.
- > Keep tight grip on the handles/grip surface.
- > Maintain this product in accordance with these instructions and keep it well lubricated (where appropriate).
- > Plan your work schedule to spread any high vibration tool use across a number of days.

Emergency

Familiarise yourself with the use of this product by means of this instruction manual. Memorise the safety directions and follow them to the letter. This will help to prevent risks and hazards.

- > **Always be alert when using this product, so that you can recognise and handle risks early.** Fast intervention can prevent serious injury and damage to property.
- > **Stop the engine and unplug the spark plug connector if there are malfunctions.** Have the product checked by a qualified professional and repaired, if necessary, before you operate it again.
- > **In case of fire, stop the engine and unplug the spark plug connector.** Take fire-extinguishing measures immediately if the product switch is no longer accessible.



WARNING! Never use water to extinguish a product on fire. Burning fuel must be extinguished with special extinguishing agents. We recommend that you keep a suitable fire extinguisher within reach in your work area

Residual risks

Even if you are operating this product in accordance with all the safety requirements, potential risks of injury and damage remain. The following dangers can arise in connection with the structure and design of this product:

- > Health defects resulting from vibration emission if the product is being used over long periods of time or not adequately managed and properly maintained.
- > Injuries and damage to property due to broken application tools or the sudden impact of hidden objects during use.
- > Danger of injury and property damage caused by flying objects.
- > Injuries and damage to property due to thrown and fallen objects.
- > Prolonged use of this product exposes the operator to vibrations and may produce 'whitefinger' disease. In order to reduce the risk, please wear gloves and keep your hands warm. If any of the 'whitefinger' symptoms appear, seek medical advice immediately. 'Whitefinger' symptoms include: numbness, loss of feeling, tingling, pricking, pain, loss of strength, changes in skin colour or condition. These symptoms normally appear in the fingers, hands or wrists. The risk increases at low temperatures.



WARNING! This product produces an electromagnetic field during operation! This field may under some circumstances interfere with active or passive medical implants! To reduce the risk of serious or fatal injury, we recommend persons with medical implants to consult their doctor and the medical implant manufacturer before operating this product!

Symbols

On the product, the rating label and within these instructions you will find among others the following symbols and abbreviations. Familiarise yourself with them to reduce hazards like personal injuries and damage to property.

kW	Kilowatt	cm ³	Cubic centimetre
min ⁻¹	Per minute	mm	Millimetre
kg	Kilogram	g/kWh	Gram per kilowatt hour
dB(A)	Decibel (A-rated)	m/s ²	Metres per seconds squared
mm.yyyy: Manufacturing date code, year of manufacturing (yyyy) and month of manufacturing (mm)			



Caution / Warning



Wear a helmet, safety goggles and hearing protection.



Read the instruction manual.



Wear safety footwear.



Wear protective gloves.



Wear respiratory protection.



Tip contact may cause the guide bar to move suddenly upward and backwards what may cause serious injury to user.



Always use the product with two hands. Do not use one handed when operating the product.



Correct direction of cutting-teeth. Location: on chain cover.



Location of starter handle: pull upwards.



Choke positions: CLOSED or OPEN. (This marking for the choke lever is located at the right side of the air filter cover.)



Release to stop; location: above throttle lever on main handle



Primer.



Chain brake disengaged/ engaged; location: on right side cover.



Refill chain oil here; location: Chain oil tank cap.



Indication of chain oil adjuster nut; location: bottom



Objects thrown by the product could hit the user or other bystanders. Always ensure that other people and pets remain at a safe distance from the product when it is in operation. In general, children must not come near the area where the product is.



Risk of fire / flammable material.



Hot surface, do not touch. The high temperatures on the product's surfaces and structural parts could cause burns if touched. The product can also remain hot for a long period of time after operation!



This product produces noxious exhaust fumes. If the product is not used properly, these fumes can lead to poisoning, a loss of consciousness or death!



Always unplug the spark plug connector before performing inspection, maintenance and cleaning work!



40 : 1

Only use petrol/oil mixture with a ratio of 40:1. Do not use any other mixture ratio. Always switch the product off and let it cool down, before refuelling it.



Naked flames in the work area, around the product and in the vicinity of flammable materials are prohibited!



Do not smoke in the work area, around the product and in the vicinity of flammable materials!



Guaranteed sound power level value in dB



The product complies with the applicable European directives and an evaluation method of conformity for these directives was done.

MCSWP40 Designation of the tool (M_MacAllister brand; CSW_Chainsaw P_Petrol Power

Your product

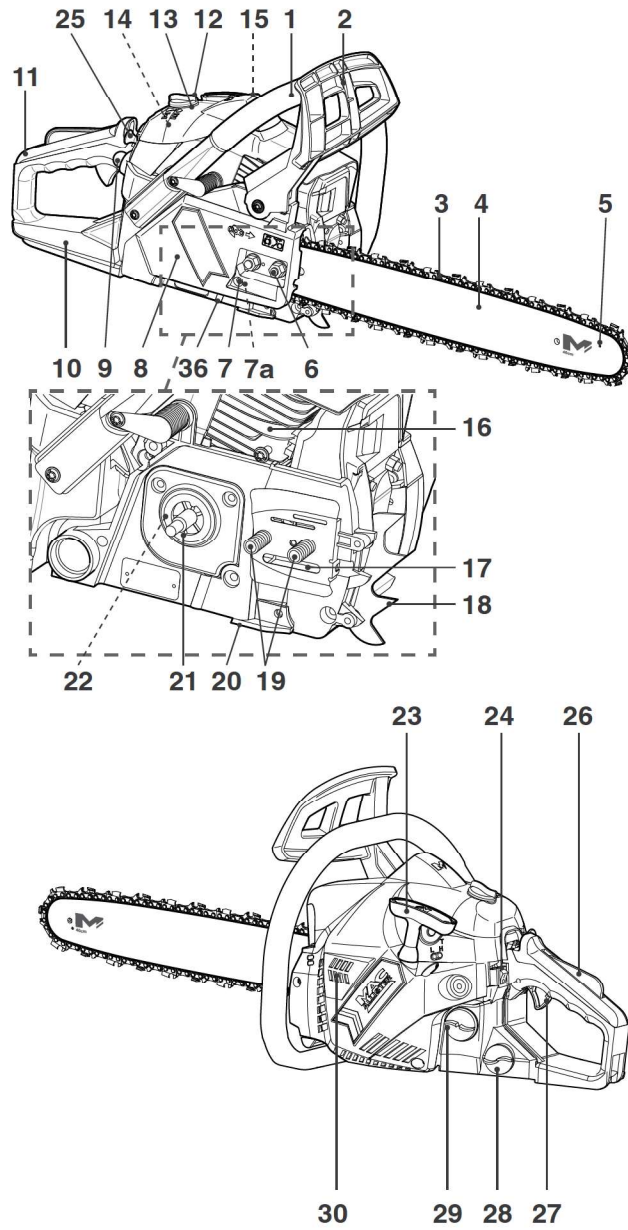

Getting Started...

Your product

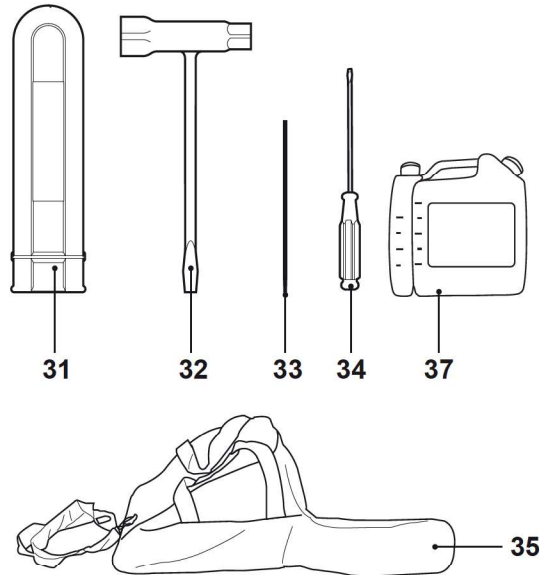

- | | |
|----------------------------|---|
| 1. Front handle | 20. Chain catcher |
| 2. Front guard/chain brake | 21. Clutch |
| 3. Saw chain | 22. Drive sprocket |
| 4. Guide bar | 23. Recoil starter handle |
| 5. Sprocket nose | 24. Ignition switch (on/off) |
| 6. Nuts | 25. Choke lever |
| 7. Tension screw | 26. Throttle interlock |
| 7a. Tension pin | 27. Throttle trigger |
| 8. Cover | 28. Chain oil tank cap |
| 9. Primer | 29. Fuel tank cap |
| 10. Rear Guard | 30. Air vents |
| 11. Rear handle | 31. Guide bar cover |
| 12. Fixing screw | 32. Combination of spanner/spark
plug wrench |
| 13. Air filter cover | 33. Chain file |
| 14. Air filter | 34. Screwdriver |
| 15. Spark plug connector | 35. Bag |
| 16. Cylinder fins | 36. Oil adjuster screw |
| 17. Oiling port | 37. Mixing bottle |
| 18. Spike bumper | |
| 19. Bolts | |

Technical specifications

General

- > **Engine type** : 1E41F, 2 stroke petrol engine, air-cooled
- > **Engine displacement** : 40.1 cm³
- > **Max. speed** : 12000 min⁻¹
- > **Recommended speed at idling** : 3100 min⁻¹ ± 400
- > **Clutch engagement speed** : 4750 min⁻¹
- > **Max. engine power (in accordance with ISO 7293)** : 1,5 kW
- > **Cutting length** : 37 cm
- > **Guide bar length** : 406 mm (16")
- > **Guide bar type** : Oregon 160SDEA041
- > **Saw chain type** : Oregon 91P057X
- > **Chain pitch** : 9,525 mm (0,375")
- > **Chain gauge (thickness of drive links)** : 1,27 mm (0,050")
- > **Drive sprocket (teeth and pitch)** : 6 teeth x 9,525 mm
- > **Spark plug** : BOSCH L8RTF
- > **Spark plug gap** : 0,5 mm
- > **Fuel consumption at max. engine power** : 0,7 kg/h
- > **Specific fuel consumption at maximum engine power** : 560 g/kWh
- > **Fuel type** : Petrol oil mixture 40:1 for oil type see page 22
- > **Fuel tank volume** : 310 cm³ (ml)
- > **Chain oil type** : SAE #10W-30 all year round or SAE #30~#40 in summer and SAE #20 in winter
- > **Chain oil tank volume** : 190 cm³ (ml)
- > **Unit mass (without guide bar and chain Empty tanks)** : approx. 4,65 kg
- > **Max. chain speed** : 22,9 m/s

Sound level according to EN ISO 3744, ISO 22868 and 2000/14/EC

- > **Sound pressure level L_{pA}** : 100 dB(A)
- > **Sound power level L_{WA}** : 111 dB(A)
- > **Uncertainty K_{pA} , K_{WA}** : 2,5 dB(A)
- > **Guaranteed power level L_{WA}** : 114 dB(A)

Hand arm vibration according to ISO 22867

- > **Front handle $a_{hv^{2}eq}$** : 7,426m/s²
- > **Rear handle $a_{hv^{2}eq}$** : 7,780 m/s²
- > **Uncertainty K** : 1,5 m/s²

The sound intensity level for the operator may exceed 80 dB(A) and sound protection measures are necessary. The declared vibration value has been measured in accordance with a standard test method and may be used for comparing one product with another. The declared vibration value may also be used to evaluate the exposure for the user caused by vibration in advance..



WARNING! Depending on the actual use of the product the vibration values can differ from the declared total! Adopt proper measures to protect yourself against vibration exposures! Take the whole work process including times the product is running under no load or switched off into consideration! Proper measures include among others regular maintenance and care of the product and application tools, keeping hands warm, periodical breaks and proper planning of work processes!.

Unpack

- > Unpack all parts and lay them on a flat, stable surface.
- > Remove all packing materials and shipping devices if applicable.
- > Make sure the delivery contents are complete and free of any damage. If you find that parts are missing or show damage do not use the product but contact your dealer. Using an incomplete or damaged product represents a hazard to people and property.
- > Ensure that you have all the accessories and tools needed for assembly and operation. This also includes suitable personal protective equipment.

You will need

(items not supplied)

Petrol
Engine oil
Fuel funnel with filter
Saw chain oil
Grease for sprocket
nose lubrication

(items supplied)

Guide bar cover
Combination of spanner/spark
plug wrench
Screwdriver
Chain file
Mixing bottle

Assembly (if not already assembled)



NOTE: Always loosen the guide bar nuts before tensioning the chain.

Disconnect the spark plug connector (15) from the spark plug. Assemble the guide bar and saw chain before operation. Follow the operating instructions step-by-step and use the pictures provided as a visual guide to easily assemble the product.



WARNING! Read all the instructions carefully! Do not start the product before it is completely assembled. Always wear gloves during assembly!

Chain and guide bar

- > Use only the guide bar (4) and saw chain (3) according to the technical data of the product.



WARNING! Always use a saw chain designed as “low-kickback” or a saw chain which meets the low-kickback requirements! A standard saw chain (a chain which does not have the kickback reducing guard links) should only be used by an experienced professional operator! Nevertheless, a low-kickback saw chain does not completely eliminate kickback! A low-kickback or “safety” chain should never be regarded as complete protection against injury! Therefore always use a low-kickback saw chain in conjunction with other kickback protection devices such as the front guard/chain brake!

- > Place the product on a suitable flat surface with the cover (8) facing upwards.



WARNING! Before removing, ensure the front guard/chain brake (2) is in the disengaged position (see section “In more Detail - Chain brake”). If in the engaged position, pull the front guard/chain brake backwards until it ‘clicks’ into position.

- > Loosen the nuts [6] and remove the cover [8] (Fig. 1/2)

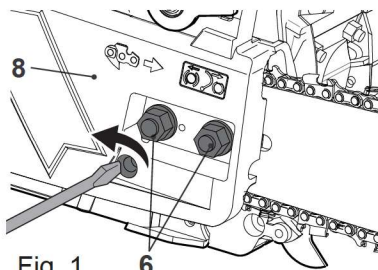

Fig. 1

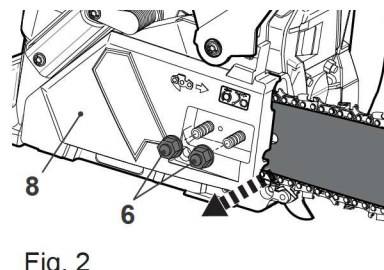

Fig. 2

- > Remove the cover and spacer plate from the bolts (19) (the spacer plate is not to be re-fitted)(Fig. 3).
- > Place the slot in the guide bar (4) over the bolts (19). Push the guide bar (4) to the left towards the drive sprocket (22) (behind the clutch (21) (Fig. 4).
- > Spread the saw chain (3) over the sprocket (22) behind the clutch (21) and fit around the guide bar (4) with the cutting edges of the chain pointing in the rotational direction (Fig. 5).
- > Slide the chain into the groove around the guide bar (Fig. 6).

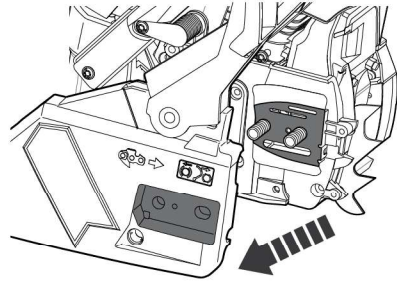

Fig. 3

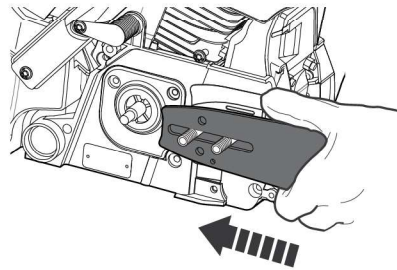

Fig. 4

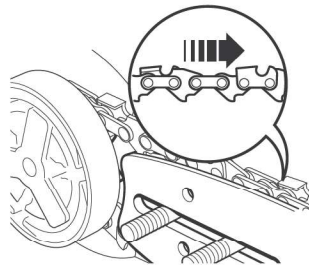

Fig. 5

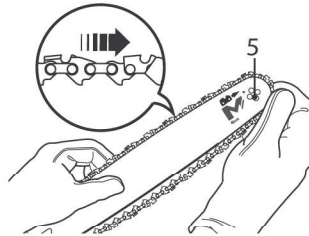

Fig. 6



WARNING! The direction of the saw chain 'cutters' must be as indicated by the symbol and arrow on the guide bar!

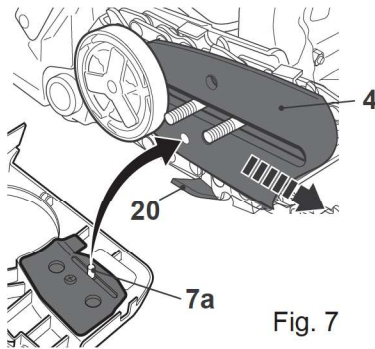

Fig. 7

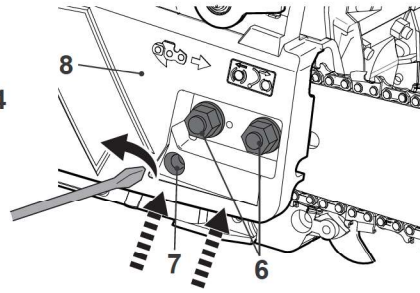

Fig. 8

- > Make sure the chain is placed above the chain catcher (20) (Fig. 7).
- > Pull the guide bar (4) carefully towards the right to pre-tighten the saw chain (3) (Fig. 7)
- > Replace the cover in place and screw in the nuts lightly (Fig.8).
- > Make sure that tension pin (7a) is well placed in the bottom hole of the the chain guide



NOTE: The saw chain (3) has not yet been tensioned. Tension the chain as described under "Saw chain tensioning". After operating the product for approximately 1 hour, adjust the chain tension again.

Saw chain tensioning

Always check the saw chain tension before use, after first cuts and regularly during use, approximately every five cuts. After initial operation, new chains can lengthen considerably. This is normal during the break-in period and the interval between future adjustments will lengthen quickly.



WARNING! Always disconnect the spark plug connector before adjusting the saw chain tension! The cutting edges of the saw chain are sharp. Always wear protective gloves when handling the chain! Always maintain proper chain tension! A loose chain increases the risk of kickback! A loose chain may jump out of the guide bar groove! This may injure the operator and damage the chain! A loose chain will cause rapid wear to the chain, guide bar and sprocket! Tensioning the chain too tightly will overload the motor and cause damage, and insufficient tension can cause chain derailing, whereas a correctly tightened chain provides the best cutting characteristics and prolonged working life! The chain life mainly depends upon sufficient lubrication and correct tensioning!

After adjusting the chain tension, reconnect spark plug connector.

- > Lift up the tip of the guide bar (4) and keep it there as you adjust the tension.
- > Turn the tension screw (7) until the chain "tie straps" are just touching the bottom edge of the guide bar (4) (Fig. 9).
- > Check the chain tension using one hand to lift the saw chain (3) against the weight of the product. The correct chain tension is achieved when the saw chain can be lifted by approximately 2 - 4 mm from the guide bar (4) in the centre (Fig.10).

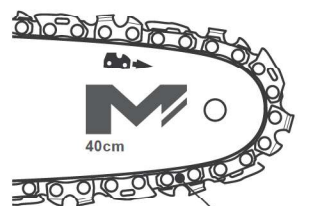

Fig. 9

Chain "tie straps"

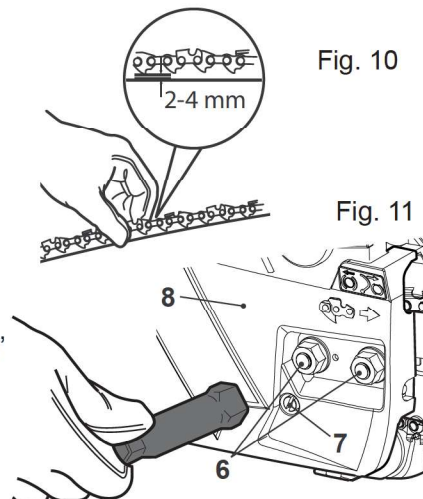

Fig. 10

Fig. 11

- > Turn the locking nuts (6) to tighten the cover (8) completely (Fig. 11).

Fuel and engine oil



WARNING! This product is not supplied with fuel-oil mixture in the engine! Before operating this product it is essential to fill it with fuel-oil mixture!

40 : 1



This product is equipped with a 2-stroke engine, the fuel and oil tank are combined and it is essential to fill a fuel-oil mixture before operating this product. Observe the technical specifications for suitable fuel and engine oil.



WARNING! Fuel and oil are highly inflammable! Fumes will explode if lit! Ensure that there are no naked flames around the product! Do not smoke while filling fuel and oil!



- > Place the product on a stable, level surface. We recommend laying a non-flammable sheet under the product.
- > Mix a regular grade unlead petrol and a quality engine oil with the supplied mixing bottle [22] (Fig. 13).
- > Use an anti-oxidant added quality oil expressly labelled for air-cooled 2 stroke engine use (JASO FC GRADE OIL or ISO EGC GRADE).
- > Do not use BIA or TWC (2 stroke water-cooling type) mixed oil
- > The recommended mixing ratio for petrol:oil is 40:1.
- > The table indicates a reference for the quantities of petrol and oil to use for the preparation of the mixture.

Petrol	Oil
[ml]	[ml]
100	2,5
200	5,0
300	7,5
400	10,0
500	12,5



Fig. 13

- > Only use the scale 40:1 of the mixing bottle as reference for this product.
- > Petrol and oil have to be filled in respective sides accordingly to the scale marking on the bottle. For example, fill petrol to scale marking "5" first, and then fill 2-stroke oil to scale marking "5". This indicates a correct ratio of 40:1 when using the scale 40:1.
- > By tilting the tank, the oil falls into the petrol. Shake the bottle thoroughly to make the mixture.



NOTE: Never mix fuel and oil directly in the tank of the product.

- > Unscrew and remove the fuel tank cap (29).
- > Fill correctly mixed fuel/oil into the tank using a fuel funnel fitted with a filter to avoid debris entering the tank. Do not overfill. Leave a minimum 5 mm of space between the top of the fuel and the inside edge of the tank to allow for expansion (Fig. 14).
- > Avoid spilling and overfilling the tank.
- > Wipe up spilled fuel with a soft cloth and refit the fuel tank cap (29). Use the combination spanner (32) to tighten the cap (29) properly (Fig. 15).
- > Always dispose of fuel, used oil and soiled objects according to local regulations (see section "Recycling and disposal").

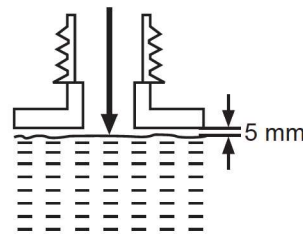

Fig. 14

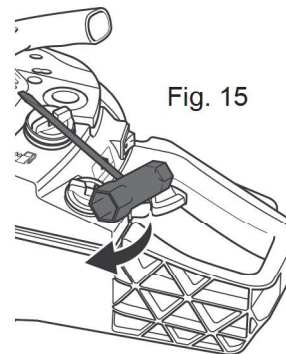

Fig. 15



40 : 1



NOTE: Fuel and oil deteriorate over time. It may be difficult to start the engine if you use fuel which has been kept for more than 30 days. Towards the end of the season, it is advisable to put only as much fuel in the tank as you need for each use, since it should be completely used up before storing the product. Empty remaining fuel from the tank when storing the product for over 30 days.

Chain lubrication

Filling



WARNING! The product is not filled with chain oil. It is essential to fill the product with chain oil before using it! Never operate the product without chain oil as this will result in extensive damage to the product!! Operating the saw chain dry or with too little chain oil will decrease cutting efficiency, shorten the product life span and cause rapid wear to the saw chain and guide bar from overheating! Insufficient chain oil is evident by smoke or bar discoloration! Adequate lubrication of the saw chain during cutting operations is essential to minimise friction with the guide bar!

- > Set the product on any suitable surface with the chain oil tank cap (28) facing upwards.
- > Unscrew and remove the tank cap (28), then add the lubricant into the tank. Use Chainsaw chain oil.
- > Use a proper funnel with a filter to prevent debris entering the tank and to avoid spilling and overfilling the tank. Do not overfill and leave approximately 5 mm of space to the lower edge to allow the lubricant to expand (Fig. 16).
- > Wipe up spilled oil with a soft cloth and refit the chain oil tank cap (28). Use the combination spanner (32) to tighten the cap (28) properly (Fig. 17).

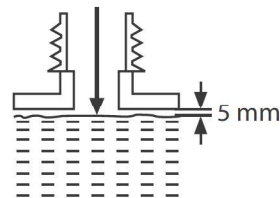

Fig. 16

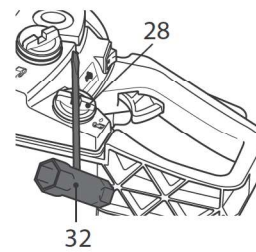

Fig. 17



NOTE: Always dispose of lubricant, used oil and objects contaminated with them in accordance with local regulations.

Checking

- > Check the chain lubrication before each use.



NOTE: This product is equipped with an automatic oiling system! The oiling system automatically delivers the proper amount of oil to the bar and chain! Checking the lubrication requires starting the engine. Before checking the product must be fully assembled and all instructions must have been read.

- > Make sure the guide bar (4) and the saw chain (3) are in place when you check the oil delivery.
- > Start the engine; keep it running at medium power and check if the chain oil is delivered as shown in the figure (Fig. 18).
- > Adjust the chain oil flow using screwdriver (34) on the oil adjuster screw (36), which is on the bottom of the product (Fig. 19).

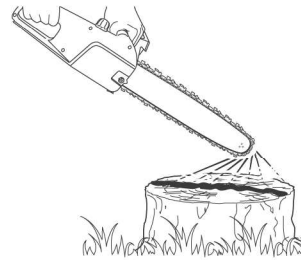

Fig. 18

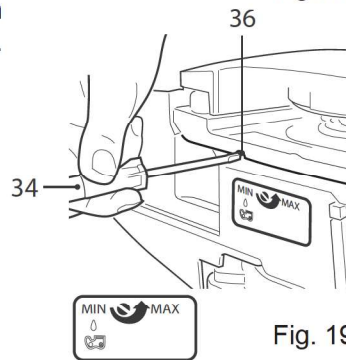
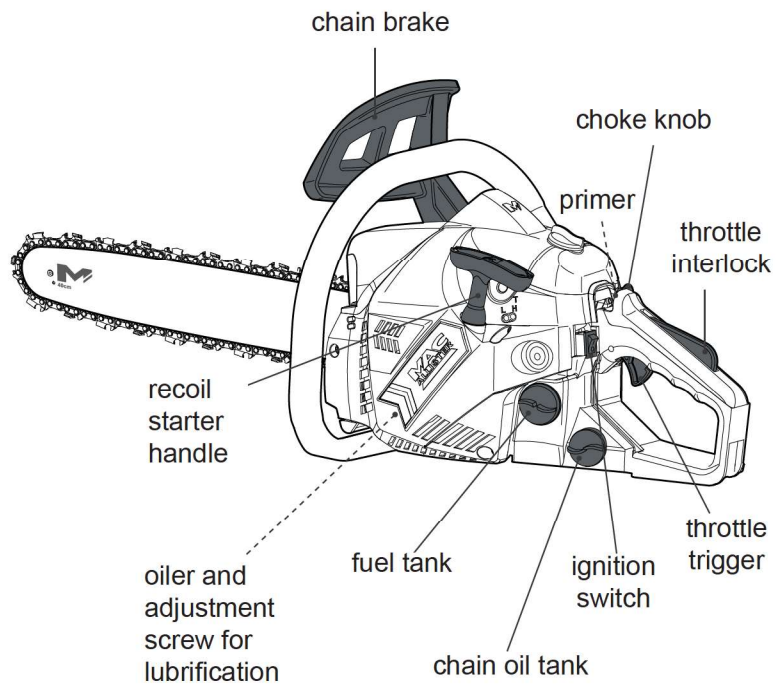

Fig. 19

Operating controls



Set up



Assemble



Adjust

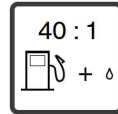

Add fuel /
oil mixture



Add chain oil

Cold start or starting after running out of fuel



Engage
chain brake



Set ignition
switch to "I"



Pull out
choke
lever fully



Press primer
x6 until fuel is
visible



Pull recoil
starter handle
x4 (the
machine still
should not
start)



Press the
choke
lever in



Pull recoil
starter handle
until engine
starts



Press and
release the
throttle interlock
and throttle
lever to cancel
fast tickover



Disengage
the chain
brake



Operate

Warm start



Engage chain brake



Set ignition switch to "I"



Pull out choke lever fully



Push choke lever back in



Pull recoil starter handle until engine starts



Press and release the throttle interlock and throttle lever to cancel fast tickover



Disengage the chain brake.



Operate

Stopping



Release throttle lever and interlock



Set ignition switch to "O".



Empty tanks



Clean and maintain



Store



WARNING! This quick start provides only a short overview of how to start and stop the product! For safe use it is essential to read the entire instruction manual before first use!



In more detail...

Product functions	30
Operation	35
Care and maintenance	43
Trouble shooting	54
Recycling and disposal	55
Guarantee	56
EC declaration of conformity	57

In more detail...

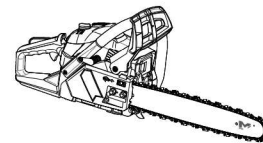

Intended use

This petrol chain saw MCSWP40 is designated with a maximum power output of 1.5 kW. The product is intended for cutting logs with a thickness of max. 370 mm with the guide bar provided. It must not be used for cutting other materials, such as plastic, stone, metal or wood that contains foreign objects. The product may only be used with the guide bar/saw chain combination stated in these instructions. It is not permitted to use other types or sizes because it can result in serious personal injury or death. Vertical and horizontal cuts can be performed with this product. Longitudinal sections can only be cut by professionals. This product should not be used outside of domestic premises e.g. for cutting firewood in forested areas. The product should not be used on masonry and materials that are harmful to health. This product is intended for private domestic use only, not for any commercial trade use. It must not be used for any purposes other than those described.

Primer

Press the primer (9) 6 times when starting the product with a cold engine (Fig. 20). Do not press the primer for warm starts.

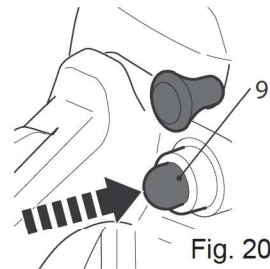

Fig. 20

Choke lever and fast tickover

1. By pulling out the choke lever (25) fully (Fig. 20a), the choke is now at CLOSE position, and the throttle is at fast tickover.
2. By pressing in the choke lever (Fig. 20b), the choke is now at OPEN position while the throttle is kept at fast tickover.
3. To cancel fast tickover, press and release the throttle interlock (26) and throttle trigger (27).

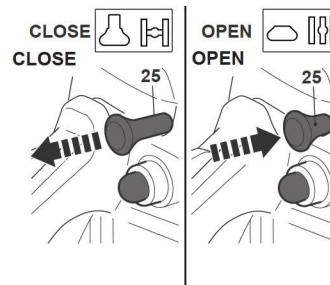

Fig. 20a

Fig. 20b



NOTE: It is easier to start the engine by setting the throttle at fast tickover. When the throttle fast tickover is cancelled, the engine runs at idle speed.

Chain brake

The chain brake is a safety mechanism activated by the front guard (2). When kickback occurs the chain stops immediately.

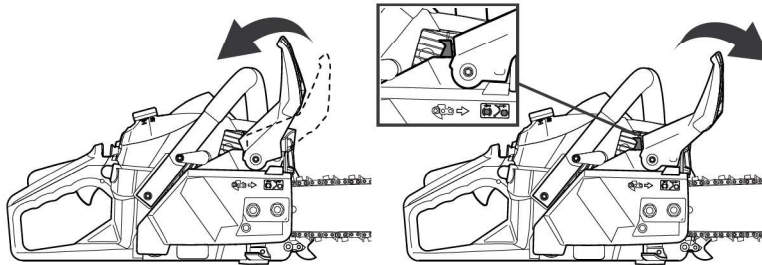

The chain brake (2) in the disengaged position, the product can be operated (Fig. 21)

The chain brake (2) in the engaged position, the saw chain is stopped as soon as the chain brake is activated (Fig. 22)

Chain brake test

The following functional check should be carried out before each use. The purpose of the chain brake test is to reduce the possibility of injury due to kickback.

- > Make sure the chain brake (2) is disengaged. Disengage the chain brake (2) by pulling it back towards the front handle (1) (Fig. 21).
- > Place the product on any suitable flat surface, make sure the saw chain (3) is not touching the surface or other objects.
- > Grasp the front handle (1) with your left hand. Your thumb and fingers should encircle the handle. Grasp the rear handle (11) with your right hand. Your thumb and fingers should encircle the handle (Fig. 23).
- > Start the product as described, press the throttle interlock (26), then fully squeeze in the throttle trigger (27) with your index finger and hold in this position



Fig. 23

- > Activate the chain brake (2) whilst the engine is running by moving your left hand forward against the chain brake (2). The saw chain (3) should stop immediately.



NOTE: The chain will not start if the chain brake is in the engaged position.

DO NOT accelerate the engine for more than 10 seconds when the chain brake (2) is in engaged position (Fig.22), as the chain brake system inside may damage the machine.



WARNING! If the saw chain fails to stop when the chain brake is engaged, take the product to the nearest authorised dealer or service centre! Do not use the product if the chain brake is not working properly!

Starting / Stopping

Cold start



NOTE: The machine is equipped with a device (easy starter) that allows an easy start.

This device changes the method of pulling the recoil starter handle.

The first part of the cord stroke serves to pre-charge the device while the starting force develops towards the end of the stroke.

- > Make sure the safety chain brake is engaged by pushing the front guard (2) fully forwards. (See above, page 31).
The saw chain will not start if the chain brake is in the engaged position.
- > Ensure the saw chain (3) does not come into contact with anything before starting the engine.
- > Set the ignition switch (24) to position "I" (Fig. 24).

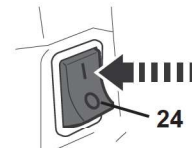

Fig. 24

- > Pull out the choke lever fully. The choke lever is now at CLOSE position and throttle is set at fast tickover position (Fig.25).
- > Press the primer (9) 6 times until the bubble is filled with fuel (Fig. 26).

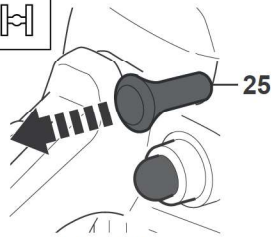
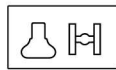

Fig. 25

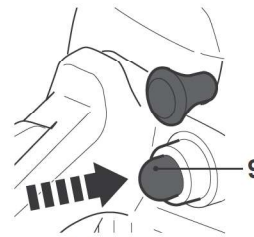
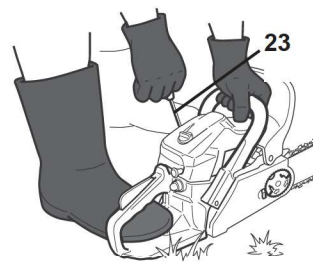

Fig. 26

- > Hold the product securely to the ground and put your foot on the rear guard (10).
- > Pull the handle on the starter cord [23] slowly with your right hand until you feel a definite resistance and then give it a brisk, strong pull. Repeat 4 or 5 times consecutively (Fig. 27). At this stage the engine still should not start.



10

Fig. 27

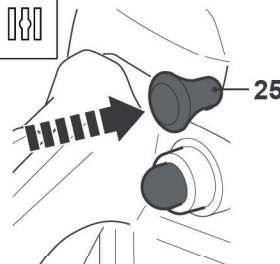

Fig. 27a

- > Press the choke lever back in (Fig. 27a). The choke lever is now at OPEN position, and throttle is kept at the fast tickover position.
- > Pull the starter cord slowly with your right hand until you feel a definite resistance and then give it a brisk, strong pull. Repeat until the engine starts.
- > Squeeze and release the throttle interlock (26) and the throttle trigger (27) to cancel fast tickover. The engine runs at idle speed.
- > Before accelerating the engine, make sure the chain brake is disengaged by pulling back the front guard (2) fully.
- > Squeeze the throttle interlock and throttle trigger to accelerate the engine. The saw chain runs.

- > Push the front guard (2) to check if the chain brake works properly. Then disengage the chain brake.
- > To use the chainsaw grip the product with both hands, left hand holding the front handle (1) (do not hold chain brake) and the right hand holding the rear handle (11).

Warm Start:

- > Make sure the safety chain brake is engaged by pushing the front guard (2) fully forwards. (See above, page 31). The saw chain will not start if the chain brake is in the engaged position.
- > Ensure the saw chain (3) does not come into contact with anything before starting the engine.
- > Set the ignition switch (24) to position "I" (Fig. 24)
- > Pull out the choke lever (25) fully and then press it in. The choke is now at OPEN position and the throttle is set at fast tickover position.
- > Hold the product securely to the ground and put your foot on the rear guard (10).
- > Pull the starter cord [23] slowly with your right hand until you feel a definite resistance and then give it a brisk, strong pull. Repeat until the engine starts.



WARNING! Allow the starter cord to return slowly and in a controlled manner each time it is pulled!



NOTE: When you squeeze and release the throttle interlock (26) and throttle trigger (27), the fast tickover is cancelled and engine runs idle.

- > Before accelerating the engine, make sure the chain brake is disengaged by pulling back the front guard (2) fully.
- > Squeeze the throttle interlock and throttle trigger to accelerate the engine. The saw chain runs.
- > Push the front guard (2) to check if the chain brake works properly. Then disengage the chain brake.
- > To use the chainsaw, grip the product with both hands, left hand holding the front handle (1) (do not hold chain brake) and the right hand holding the rear handle (11).

Stopping

- > Release the throttle trigger (27) and let the product run in idle for a while.
- > Set the ignition switch (24) to "O" (off position) (Fig. 28).

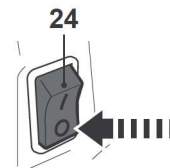

Fig. 28



WARNING! The product will continue to work for some time even after the engine has been switched off! Wait until it comes to a complete stop before you put the product down!

General operation

- > Check the product, as well as accessories for damage before each use. Do not use the product if it is damaged or shows wear.
- > Double check that accessories and the guide bar/saw chain are properly fixed.
- > Check the fuel / oil mixture level and chain oil level, refill if necessary.
- > Always hold the product by its handles. Keep the handles dry and free from lubrication to ensure safe support.
- > Ensure that the air vents are always unobstructed and clear. Clean them if necessary with a soft brush. Blocked air vents may lead to overheating and damage the product.
- > Switch the product off immediately if you are disturbed while working by other people entering the working area. Always let the product come to complete stop before putting it down.
- > Do not overwork yourself. Take regular breaks to ensure you can concentrate on the work and have full control over the product.

Basic operating / cutting procedure

- > To become proficient attend a recognised chain saw training course to learn how to operate chain saws safely and effectively. Familiarise yourself with all the controls and switches. Practise all movements with the product switched off.
- > Always hold the product firmly with both hands. Hold the front grip with your left hand and the rear grip with your right hand. Fully grip both handles at all times during operation. Never operate the product using only one hand.
- > Only use the product with a secure stance. Hold the product to the right-hand side of your body (Fig. 29).

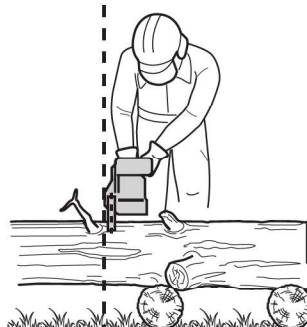

Fig. 29

In more detail...

- > The saw chain (3) must be running at full speed before it makes contact with the wood. Use the spike bumper (18) to secure the product onto the wood before starting to cut and use it as a leverage point while cutting (Fig. 30).

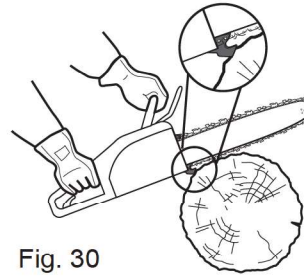

Fig. 30

- > Reset the spike bumper at a low point when cutting thicker logs by pulling the product slightly backwards until the gripping teeth release, and then reposition at lower level to continue sawing. Do not remove the product completely from the wood.
- > Do not force the saw chain while cutting, let the chain do the work using the gripping teeth to apply minimal leverage pressure.
- .
- > Do not operate the product with your arms fully extended or attempt to saw areas which are difficult to reach or while on a ladder. Never use the product above shoulder height. (Fig. 31).

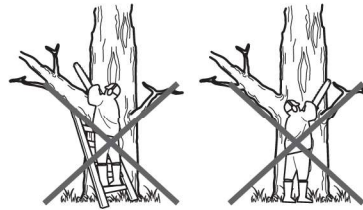

Fig. 31

- > Optimum sawing is achieved if the chain speed remains constant during cutting.
- > Be careful when reaching the end of the cut. The weight of the product may change unexpectedly as it cuts free from the wood. This can cause accidents to the legs and feet. Always remove the product from a wood cut while the product is running.

Kickback



WARNING! Beware of kickback! Kickback can lead to dangerous loss of control of the product and result in serious or fatal injury to the operator or anyone standing close by! Always be alert because rotational kickback and pinch kickback are major product operational dangers and the leading cause of most accidents!

Kickback may occur if the nose or tip of the guide bar touches an object, or if wood pinches the saw chain in the cut.

In some cases, contact with the tip of the guide bar (4) may cause a lightning-fast reverse reaction, kicking the guide bar up and back toward the operator (Figs. 32 - 34).

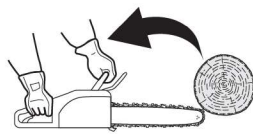

Fig. 32

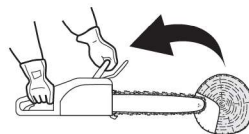

Fig. 33

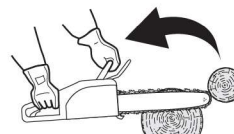

Fig. 34

- > Pinching of the saw chain (3) along the bottom of the guide bar (4) may pull the product forward away from the operator (Fig. 35).

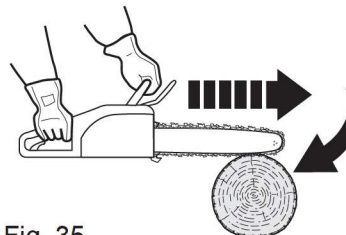

Fig. 35

- > Pinching of the saw chain (3) along the top of the guide bar (4) may push the guide bar rapidly back toward the operator (Fig. 36).

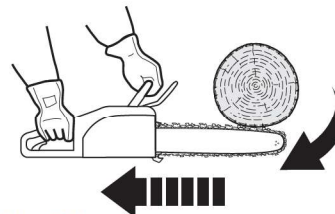

Fig. 36

- > Any of these reactions may cause a loss of control over the product, which could result in serious personal injury or even death.

- > With a basic understanding of 'kickback', the element of surprise can be reduced or eliminated. Sudden surprise contributes to the majority of accidents.
- > Keep a good firm grip on the product with both hands, your right hand on the rear handle (11) and your left hand on the front handle (1), when the motor is running. Maintain a firm grip with your thumbs and fingers encircling the handles. A firm grip will help you reduce 'kickback' and maintain control of the product.
- > You should read all the safety warnings and user instructions carefully before attempting to operate this product.

To avoid kickback:

- Saw with the guide bar at a flat angle
- Never work with a loose, widely stretched or heavily worn chain.
- Ensure the chain is sharpened correctly.
- Never saw above shoulder height.
- Never work with the tip of the guide bar.
- Always hold the product firmly with both hands.
- Always use a low kickback chain.
- Apply the metal gripping teeth for leverage.
- Ensure correct chain tension.

Felling a tree

- > When bucking and felling operations are being performed by two or more persons at the same time, the felling operations should be separated from the bucking operation by a distance of at least twice the height of the tree being felled. Trees should not be felled in a manner that would endanger any person, strike any utility line or cause any property damage. If the tree does make contact with any utility line, the company should be notified immediately.
- > The product operator should keep on the uphill side of the terrain as the tree is likely to roll or slide downhill after it is felled.
- > An escape path should be planned and cleared as necessary before cuts are started. The escape path should extend back and diagonally to the rear of the expected line of fall (Fig. 37).

- > Before felling is started, consider the natural lean of the tree, the location of larger branches and the wind direction to judge which way the tree will fall.
- > Remove dirt, stones, loose bark, nails, staples and wire from the tree.

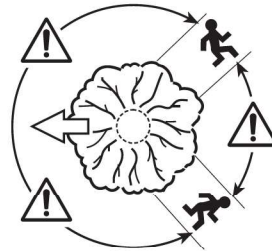

Fig. 37

Notching undercut

Make the notch (Fig. 38, B) 1/3 the diameter of the tree, perpendicular to the direction of falls (Fig. 38). Make the lower horizontal notching cut first. This will help to avoid pinching either the saw chain or the guide bar when the second notch is being made.

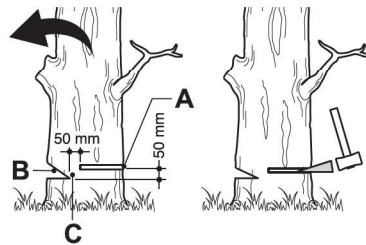

Fig. 38

Felling back cut

- > Make the felling back cut (Fig. 38, A) at least 50 mm higher than the horizontal notching cut (Fig. 38). Keep the felling back cut parallel to the horizontal notching cut. Make the felling back cut so enough wood is left to act as a hinge. The hinge (Fig. 38, C) wood keeps the tree from twisting and falling in the wrong direction. Do not cut through the hinge.
- > As the felling gets close to the hinge, the tree should begin to fall. If there is any chance that the tree may not fall in desired direction or it may rock back and bind the saw chain, stop cutting before the felling back cut is complete and use wedges of wood, plastic or aluminium to open the cut and drop the tree along the desired line of fall.
- > When the tree begins to fall remove the product from the cut, stop the motor, put the product down, then use the retreat path planned. Be alert for overhead limbs falling and watch your footing.

In more detail...

Limbing and pruning

Limbing is removing the branches from a fallen tree. When limbing leave larger lower limbs to support the log off the ground. Remove the small limbs in one cut (Fig. 39). Branches under tension should be cut from the bottom up to avoid binding the product.

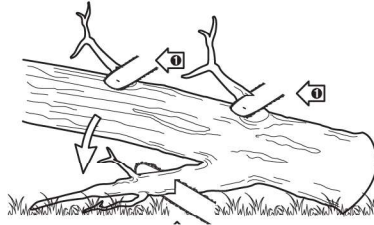

Fig. 39



WARNING! Never climb into a tree to limb or prune! Do not stand on ladders, platforms, logs, or in any position which may cause you to lose the balance or control of the saw! When pruning trees, it is important not to make the flushcut next to main limb or trunk until you have cut off the limb further out to reduce the weight! This prevents stripping the bark from the main member!



WARNING! If the limbs to be pruned are above chest height, hire a professional to perform the pruning!

Cutting spring poles

A spring pole is any log, branch, rooted stump, or sapling which is bent under tension by other wood so that it springs back if the wood holding it is cut or removed.

On a fallen tree, a rooted stump has a high potential of springing back to the upright position during the bucking cut to separate the log from the stump.

Watch out for spring poles, they are dangerous.

Bucking a log

Bucking is cutting a log into lengths. It is important to make sure your footing is firm and your weight is evenly distributed on both feet. When possible, the log should be raised and supported by the use of limbs, logs or chocks.

- > Follow the simple directions for easy cutting. When the log is supported along its entire length (Fig. 40), it is cut from the top (overbuck).

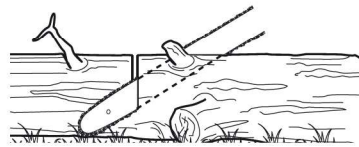

Fig. 40

- > When the log is supported on one end (Fig. 41), cut 1/3 the diameter from the underside (underbuck). Then make the finished cut by overbucking to meet the first cut.

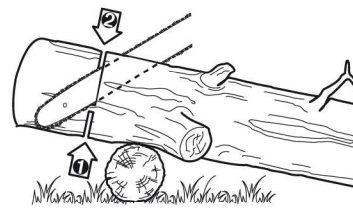

Fig. 41

- > When the log is supported on both ends (Fig. 42), cut 1/3 the diameter from the top (overbuck). Then make the finished cut by underbucking the lower 2/3 to meet the first cut.

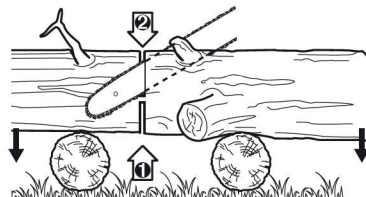

Fig. 42

- > When bucking on a slope always stand on the uphill side of the log (Fig. 43). When "cutting through", to maintain complete control release the cutting pressure near the end of the cut without relaxing your grip on the product handles. Don't let the chain contact the ground. After completing the cut, wait for the saw chain to stop before you move the product. Always stop the motor before moving from tree to tree.



Fig. 43

In more detail...

Bucking a log

- > Support small logs on a sawing stand or another log while bucking (Fig. 44).



Fig. 44

- > If the wood diameter is large enough for you to insert a soft bucking wedge without touching the chain, you should use the wedge to hold the cut open to prevent pinching (Fig. 45).

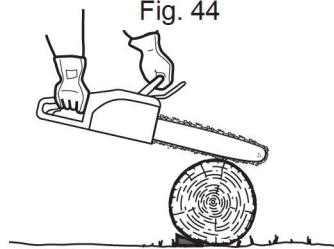

Fig. 45

After use

- > Switch the product off, and let it cool down.
- > Check, clean and store the product as described below.

The golden rules for care



WARNING! Always switch the product off, disconnect the spark plug connector and let the product cool down before performing inspection, maintenance and cleaning work!

- ① Keep the product clean. Remove debris from it after each use and before storage.
- ② Regular and proper cleaning will help ensure safe use and prolong the life of the product.
- ③ Inspect the product before each use for worn and damaged parts. Do not operate it if you find broken and worn part.



WARNING! Only perform repairs and maintenance work according to these instructions! All further works must be performed by a qualified specialist!

General cleaning

- > Clean the product with a slightly damp cloth and mild soap. Use a brush for areas that are hard to reach.
- > In particular clean the air vents (30) after every use with a cloth and brush.
- > Remove stubborn dirt with high pressure air (max. 3 bar).



NOTE: Do not use chemical, alkaline, abrasive or other aggressive detergents or disinfectants to clean this product as they might be harmful to its surfaces.

- > Check for worn or damaged parts. Replace worn parts as necessary or contact an authorised service centre for repair before using the product again.
- > Keep the chain saw in good working condition during maintenance.

Sprocket nose lubrication



NOTE: It is not necessary to remove the saw chain (3) to lubricate the sprocket nose (5). Lubrication can be done on the job.

- > Clean the sprocket nose (5).
- > Using a disposable lube gun, insert the nose of the needle into the lubrication hole (Fig. 46, A) and inject grease until it appears on the outside edge of the sprocket (5) (Fig. 46).

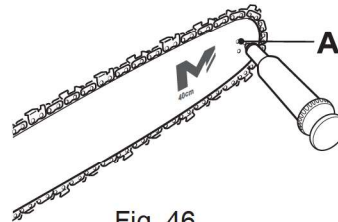

Fig. 46

- > Make sure that the chain brake (2) is deactivated. Rotate the saw chain (3) by hand. Repeat the lubrication procedure until the entire sprocket (5) has been greased.

Guide bar and saw chain maintenance

Most guide bar problems can be prevented merely by keeping the product well maintained. Incorrect filing and non-standard cutter and depth gauge settings are the causes of most guide bar problems, primarily resulting in uneven bar wear. As the bar wears unevenly, the rails widen, which may cause the chain to clatter and make it difficult to complete straight cuts. If the guide bar is insufficiently lubricated and the product is operated with a saw chain which is too tight, this will contribute to rapid bar wear. To help minimise bar wear, maintenance of the guide bar as well as the saw chain is recommended.

- > Disassemble the guide bar and saw chain in reversed order from assembly.
- > Check the oiling port (17) for clogging and clean if necessary to ensure proper lubrication of the guide bar and saw chain during operation. Use a soft wire small enough to insert into the oil discharge hole (Fig. 47).

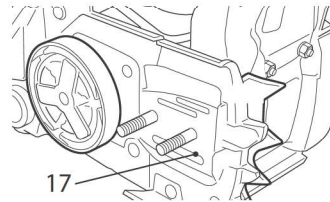

Fig. 47



NOTE: The condition of the oil passages can be easily checked. If the passages are clear, the chain will automatically give off a spray of oil within seconds of the product starting. Your product is equipped with an automatic oiling system.

- > Check the drive sprocket (22). If it is worn or damaged due to strain, have it replaced by an authorised service agent.
- > Clear residue from the rails on the guide bar (4) using a screwdriver, putty knife, wire brush or other similar tool. This will keep the oil passages open to provide proper lubrication to the bar (4) and chain (3) (Fig. 48).
- > Check the guide bar 'rail' for wear: Hold a ruler (straight edge) against the side of the guide bar and 'cutter side plates'. If there is a not gap between the ruler and guide bar the guide bar 'rail' is normal. If there is a gap (ruler flush against the side of the guide bar) the guide bar 'rail' is worn and needs to be replaced with a new one of the same type (Fig. 49).
- > Turn the guide bar 180° to allow even wear, thereby extending the life span of the guide bar (4).
- > Check the saw chain for possible wear and damages. Replace it with a new one if required. Experienced users can sharpen a dull saw chain (see section "Saw chain sharpening" below).
- > Refit the saw chain (3) and the guide bar (4) as described under "Assembly".

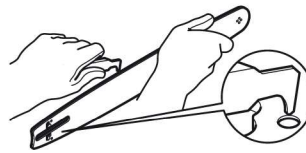

Fig. 48

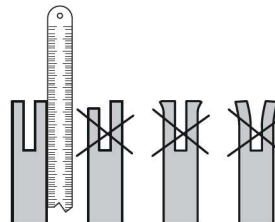

Fig. 49

In more detail...

Guide bar and saw chain maintenance

Saw chain sharpening



NOTE: Never saw with a blunt chain. The saw chain is blunt if you have to push the product into the tree and the chips are very small.

- > Have your chain (3) sharpened professionally at an authorised service centre or sharpen the chain yourself using a proper sharpening kit. Also observe the sharpening instructions supplied with the sharpening kit.



WARNING! Only sharpen the saw chain yourself if you are trained and have experience! Use proper tools to sharpen the saw chain!

- > The height difference between the tooth and the ridge is the cutting depth. When sharpening the saw chain (3) you have to consider the following points (Fig. 50).

- File angle
- Cutting angle
- File position
- Diameter of round file
- File depth

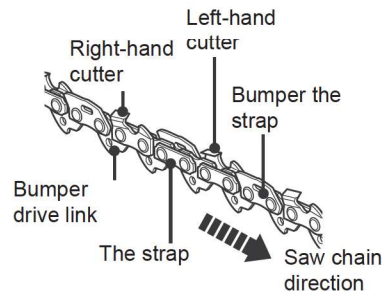

Fig. 50

- > To sharpen the chain proceed as follows:
 - Use protective gloves.
 - Ensure the chain is correctly tensioned.
 - Engage the chain brake to lock the chain on the bar.
- > Use the provided round file(33), whose diameter is 1.1 times the cutting tooth depth. Make sure 20% of the file diameter is above the cutter's top plate.

- > A file guide is available from most reputable tool merchants and is the easiest way to hold the file at the correct position.
- > File at an angle perpendicular to the bar, and at an angle of 25° to the direction of travel (Fig. 51).

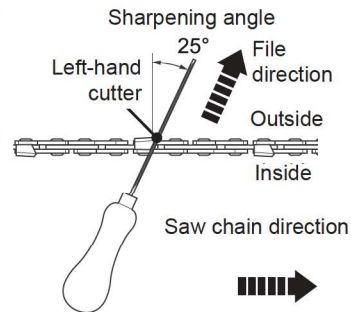

Fig. 51

- > File each tooth from the inside towards outside only. File one side of the chain first then turn the saw around and repeat the process.
- > Sharpen each tooth equally by using the same number of strokes.
- > Keep all cutter lengths equal. Check the safety depth gauge height every 5 sharpenings. If the depth gauges are also trimmed it is essential that the original profile is restored.
- > Use a depth gauge measuring instrument to check the height of the depth gauge. Depth gauge measuring jigs are available from most reputable tool merchants (Fig. 52).

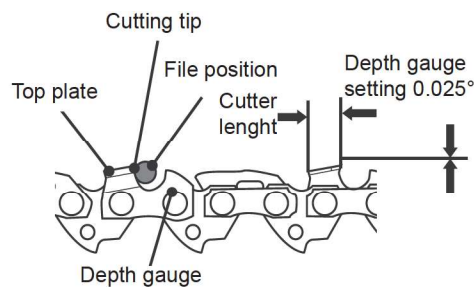

Fig. 52

In more detail...

Air filter

Inspect the air filter (14) regularly. Replace it with a new one if necessary.

- > Loosen the fixing screw (12) and remove the air filter cover (13) (Figs. 53, 54).
- > Remove the air filter (14) (Fig. 55) and split it into its two halves.
- > Brush petrol into the mesh to remove the dirt. Reassemble the air filter (14), pressing on the rims until they 'click together'.
- > Attach the air filter cover (13) and secure it with the screw (12).

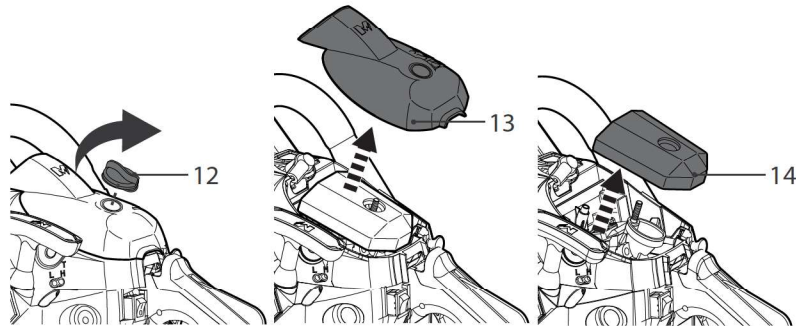

Fig. 53

Fig. 54

Fig. 55

Cylinder fins

- > Dust clogging between the cylinder fins (16) will cause overheating of the engine. Periodically check and clean the cylinder fins (16) with air jet. (Fig. 56).

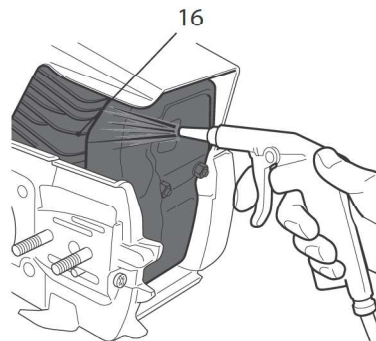

Fig. 56

Fuel Tank

- > Empty the fuel tank when storing the product over 30 days to prevent the fuel from deteriorating.
- > Unscrew and remove the fuel tank cap (29) and use a proper fuel pump to empty the fuel into a suitable container.

Fuel Filter

- > The fuel tank of this product is fitted with a filter located at the free end of the fuel pipe (Fig. 57).
- > Completely remove the fuel tank cap.
- > Use a wire hook and take the filter out from the filter port.
- > Dismantle the filter and wash with petrol.
- > After cleaning the filter, re-assemble it carefully and insert into the tank.
- > Insert the retainer and close the fuel tank cap.

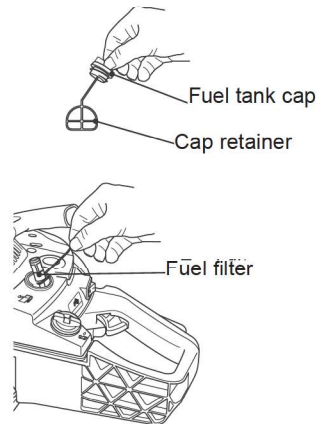

Fig. 57

In more detail...

Spark plug

- > Inspect the spark plug every 25 hours or prior to long-term storage over 30 days if the use has not been this high. Clean or replace with a new spark plug if necessary.
- > Remove the air filtercover (13) and air filter(14) as described. Disconnect the spark plug connector (15) (Fig. 58).
- > Use the combination spanner (32) to loosen and remove the spark plug (Fig. 59).

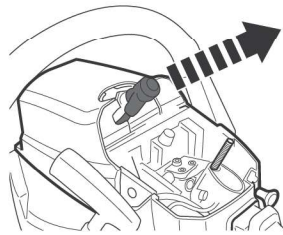

Fig. 58

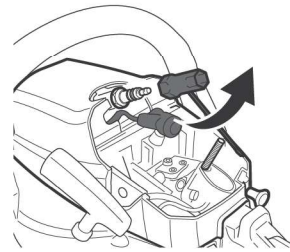

Fig. 59

- > Check the spark plug for damage and wear. The colour of the electrode should be light-brown coloured.
- > Remove debris from the electrode with a soft wired brush; avoid heavy cleaning of the electrode.
- > Dry the spark plug with a soft cloth if it is wet from fuel.
- > Check the spark plug gap. It should be 0.5 mm (Fig. 60)

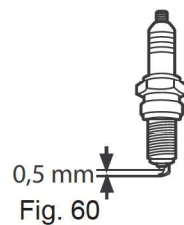

Fig. 60

- > Replace with a new spark plug if either the electrode or the insulation is damaged.
- > When replacing the spark plug, first screw it in hand tight and then lightly tighten it with the spark plug wrench (32).



WARNING! Do not over-tighten the spark plug to avoid any damage!

- > Attach the air filter cover (13) and secure it with the screw (12).

Carburettor

The carburettor is pre-set by the manufacturer. Should it be necessary to make any changes please contact an authorised service centre or a similarly qualified person. Do not attempt to make any adjustments by yourself.

If the saw chain fails to stop moving when the throttle trigger is released, please contact an authorised service centre or a similarly qualified person.

Silencer

If it be necessary to modify or replace the silencer, please contact an authorised service centre or a similarly qualified person.

Repair

This product does not contain any parts that can be repaired by the consumer. Contact a qualified specialist to have it checked and repaired.

Maintenance Table

Part	To do	Before/ after each use	10 hours	25 hours	50 hours / half year	100 hours / once a year
Cylinder fin	clean		x			
Spark plug	check			x		
Spark plug	clean			x		
Spark plug	replace	whenever necessary				
Air filter	check	x				
Air filter	clean		x			
Air filter	replace	whenever necessary				
Fuel filter	check	x				
Fuel filter	clean		x			
Fuel filter	replace	whenever necessary				
Saw chain	check	x				
Saw chain	lubricate	x				
Saw chain	clean	x				
Saw chain	replace	whenever necessary				

In more detail...

Storage

- > Clean the product as described above.
- > Store the product and its accessories in a dry, frost-free, well-ventilated place.
- > Always store the product in a place that is inaccessible to children. The ideal storage temperature is between 10 and 30°C.
- > We recommend using the bag (35) for storage or covering the product with a suitable cloth to protect it against dust.

Transportation

- > Switch the product off and disconnect the spark plug connector before transporting it anywhere.
- > Attach transportation guards, if applicable.
- > Always carry the product by its handle.
- > Protect the product from any heavy impact or strong vibrations which may occur during transportation in vehicles.
- > Secure the product to prevent it from slipping or falling over.
- > Pack the product and accessories into the bag (35).

In more detail...

Trouble shooting

Suspected malfunctions are often due to causes that the users can fix themselves. Therefore check the product using this section. In most cases the problem can be solved quickly.



WARNING! Only perform the steps described within these instructions! All further inspection, maintenance and repair work must be performed by an authorised service centre or a similarly qualified specialist if you cannot solve the problem yourself!.

Problem	Possible cause	Solution
1. Engine does not start	1.1 Not enough fuel in fuel tank 1.2 Primer has been not pressed at cold start 1.3 Primer has been pressed at warm start 1.4 Spark plug is wet 1.5 Spark plug is damaged 1.6 Spark plug connector lose	1.1 Add fuel 1.2 Press the primer and restart 1.3 Dry spark plug 1.4 Dry spark plug 1.5 Replace spark plug 1.6 Attach properly
2. Engine stops	2.1 Not enough fuel in fuel tank 2.2 Cutting device is blocked	2.1 Add fuel 2.2 Remove blockage
3. Unsatisfactory cutting performance	3.1 Saw chain not tensioned properly 3.2 Blunt saw chain	3.1 Tension properly 3.2 Sharpen or replace the saw chain
4. Excessive vibration/noise or exhaust	4.1 Saw chain is dull/damaged 4.2 Bolts/nuts are loose 4.3 Petrol/oil is incorrect	4.1 Replace with a new one 4.2 Tighten bolts/nuts 4.3 Empty out unused petrol/oil and refill with the correct petrol/oil

Service Link



This product is supported by Service Link. If you have been unable to find the information you require above please call the Service Link helpline. Here you will find 1-2-1 help and advice from garden machinery repair specialists.

Recycling and disposal

- > Waste products should not be disposed of with household waste. Please recycle where facilities exist. Check with your Local Authority or local store for recycling advice.
- > Petrol, oil, old oil, a mixture of oil and petrol and objects soiled with oil e.g. cleaning cloths do not belong in the household rubbish. Dispose of oily items in accordance with local guidelines and hand them in at recycling centres.
- > The product comes in a package that protects it against damage during shipping. Keep the package until you are sure that all parts have been delivered and the product is functioning properly. Recycle the package afterwards.

In more detail...

Guarantee

- > This product carries a guarantee of 24 months starting from the day of purchase. Please retain your receipt as a proof.
- > This guarantee specifically excludes losses due to:
 - Normal wear and tear, including accessory wear
 - Overload, misuse or neglect
 - Failure of consumable items (such as batteries)
 - Repairs attempted by anyone other than an authorized agent
 - Accidental damage caused by foreign objects or substances
 - Lack of routine maintenance
 - Failure to follow manufacturer's guidelines
 - Loss of use of the goods
- > Due to continuous product improvement, we reserve the right to change the product specification without prior notice.
- > This guarantee does not affect your statutory rights.
- > For any inquiries relating to the guarantee please contact your retailer: if you purchased this product in B&Q store or website then call 0333 014 3101. If you bought this product in SFX outlet or website then call 03330 112 112



Service Link

- > **What is Service Link?** Service Link is an aftersales help and advice helpline with a national network of garden machinery repair specialists
- > **How can we help you?** Here at service link we can help with all your trouble shooting, warranty, parts and service needs. Call us and speak to one of our advisors and if required, visit one of our 450 centres across the UK and Ireland.
- > **How can you contact us?** If in the unlikely event that this product does require our help please contact the helpline on 0800 121 6585 in the UK or 1800806149 in Rol. Lines are open Monday-Saturday 9am to 5pm and Sundays 10am to 4pm. Also find us online at www.mowerfix.info



We
Kingfisher International Products B.V.
Rapenburgerstraat 175E
1011 VM Amsterdam
The Netherlands

Declare that the product
40cc Petrol Chain Saw MCSWP40
Serial number: from 000001 999999

Complies with the essential health and safety requirements of the following Directives:

The Machinery Directive 2006/42/EC

- EN ISO 11681-1:2011
- Certificate registration number: BM 50400383 001
- Test report Nr.: 15075551 001-003
- Conformity assessment procedures: Annex IX of the directive
- Notified body: 0197, TÜV Rheinland LGA Products GmbH, Tillystrabe 2, 90431 Nurnberg Germany

The EMC Directive 2014/30/EU

- EN ISO 14982:2009

The RoHS II Directive 2011/65/EU - 2015/863/EU - (EU) 2017/2102

- EN 50581:2012

The Outdoor Noise Directive 2000/14/EC & 2005/88/EC

- Measured Sound Power Level:111 dB(A)
- Guaranteed Sound Power Level:114 dB(A)

The Emission of Pollutants Regulation EU 2016/1628

- Approval NO: e13*2016/1628*2016/1628SHA1/P*0017*02
- Engine model: 1E41F

Authorized Signatory and technical file holder:

Kingfisher International Products B.V.
Rapenburgerstraat 175E
1011 VM Amsterdam
The Netherlands

Eric Caputommino,
Director of Group Quality

A handwritten signature in blue ink, appearing to read "Eric Caputommino".

on: 24/10/2019



Manufacturer • Fabricant • Producent • Producător • Fabricante:

UK Manufacturer:

Kingfisher International Products Limited,
3 Sheldon Square, London, W2 6PX,
United Kingdom
www.kingfisher.com/products

EU Manufacturer:

Kingfisher International Products B.V.
Rapenburgerstraat 175E
1011 VM Amsterdam
The Netherlands
www.kingfisher.com/products



www.diy.com
www.screwfix.com
www.screwfix.ie

**To view instruction manuals online, visit
www.kingfisher.com/products**

1